

SW-GQ25FSL

ANTI-VANDAL PUSH BUTTON

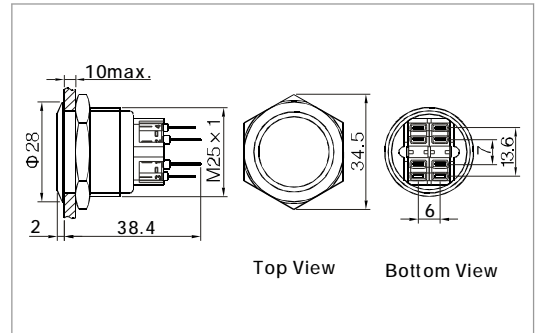

- ⊙ $\Phi 25$ mm diameter
- ⊙ Switch Rating:5A/250VAC
- ⊙ Contact Configuration:1NO1NC / 2NO2NC
- ⊙ Operation Type: Momentary
- ⊙ The crust material: Stainless Steel
- ⊙ IP Degree:IP65



Specification		SW-GQ25FSL
The Front Shape		Flat Round
Terminal Type		Pin Terminal(2.8×0.5 mm)
Switching		No.2
Max.Switch Rating		Ith:5A Ui:250VAC
Contact Resistance		≤50mΩ
Insulation Resistance		≥1000MΩ
Dielectric Strength		2000VAC
Operating Temp		-20℃ ~ +55℃
Mechanical life		1,000,000 cycles
Electrical life		50,000 cycles
Panel Thickness		1 ~ 6mm
Torque		5 ~ 14Nm
Operation Pressure		5.5 ~ 7N
Operation Distance		About2.8mm
IP Degree		IP65
Material	Contact	Silver Alloy
	Button	Stainless Steel
	Body	Stainless Steel
	Base	PA
	RoHS	Made to order